

## 产品规格书

### Specification of products

产品名称: 快恢复二极管

产品型号: MURP400200CI

浙江世菱半导体有限公司  
ZHEJIANG SHILING SEMICONDUCTOR CO., LTD.

地址: 浙江省 丽水市 莲都区

电话: (0578) 3012571 3615078

传真: (0578) 3611180

邮编: 323000

E-mail: smrshiling01@163.com

Http://www.smrshiling.com

拟制	审核	核准
林益龙	曹剑龙	宗瑞

### UltraFast Soft Recovery Diode Module

#### Description

Ultra-FRD module devices are optimized to reduce losses and EMI/RFI in high frequency power conditioning electrical systems. These diode modules are ideally suited for power converters, motor drives and other applications where switching losses are significant portion of the total losses.

#### Features

- ☞ Repetitive Reverse Voltage :  $V_{RRM}=200V$
- ☞ Low Forward Voltage Drop :  $V_f$  (typ.) = 1.0V
- ☞ Average Forward Current :  $I_{F(AV)} = 400A$  @  $T_c=100^\circ C$
- ☞ Ultra-Fast Reverse Recovery Time :  $t_{rr}$ (typ.) = 95 ns
- ☞ Extensive Characterization of Recovery Parameters
- ☞ Reduced EMI and RFI
- ☞ Non Isolation Type Package

#### Applications

Motor Drives, Free wheel use, High Power Converters, Welders, Various Switching and Telecommunication Power Supply.

#### Equivalent Circuit and Package

Equivalent Circuit

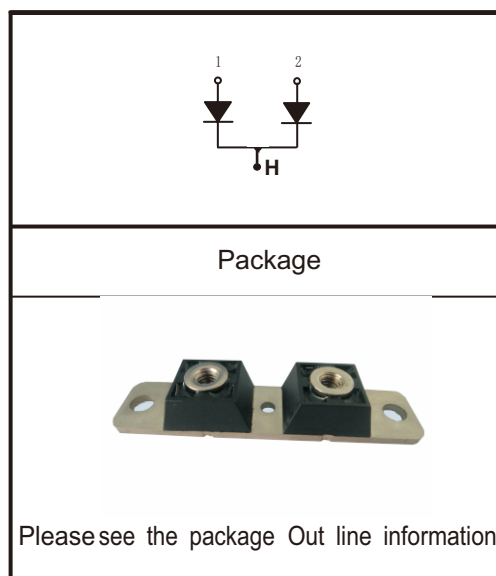

#### Absolute Maximum Ratings @ $T_j=25^\circ C$ (Per Leg)

Symbol	Parameter	Conditions	Ratings	Unit
$V_{RRM}$	Repetitive Peak Reverse Voltage		200	V
$V_{R(DC)}$	Reverse DC Voltage		160	V
$I_{F(AV)}$	Average Forward Current	Resistive Load	800 400	A A
$I_{FSM}$	Surge (non-repetitive) Forward Current	One Half Cycle at 60Hz, Peak Value	8000	A
$I^2_t$	$I^2t$ for Fusing	Value for One Cycle Current, $t_w=8.3ms, T_j=25^\circ C$ Start	$119 \times 10^3$	$A^2 s$
$T_j$	Junction Temperature		-40 ~ 125	$^\circ C$
$T_{stg}$	Storage Temperature		-40 ~ 125	$^\circ C$
$P_d$	Maximum Power Dissipation		1160	W
-	Mounting Torque		4.0	N.m
-	Terminal Torque		3.0	N.m

### Thermal Characteristics

Symbol	Parameter	Conditions	Values			Unit
			Min.	Typ.	Max.	
$R_{th(j-c)}$	Thermal Resistance	Junction to Case	-	-	0.10	°C/W

### Electrical Characteristics @ $T_j = 25^\circ\text{C}$ (unless otherwise specified)

Symbol	Parameter	Conditions	Values			Unit	
			Min.	Typ.	Max.		
$V_R$	Cathode Anode Breakdown Voltage	$I_R = 100\mu\text{A}$	200	-	-	V	
$V_{FM}$	Maximum Forward Voltage	$I_{FM} = 400\text{A}, T_c = 25^\circ\text{C}$	-	1.0	1.1	V	
		$I_{FM} = 400\text{A}, T_c = 100^\circ\text{C}$	-	0.7	0.8	V	
$I_{RRM}$	Repetitive Peak Reverse Current	$T_c = 100^\circ\text{C}, V_{RRM}$ applied	-	-	10.0	mA	
$t_{rr}$	Reverse Recovery Time	$I_{FM} = 300\text{A}, V_R = 150\text{V}, di/dt = -100\text{A}/\mu\text{s}$	$T_c = 25^\circ\text{C}$	-	65	70	ns
			$T_c = 100^\circ\text{C}$	-	100	-	ns

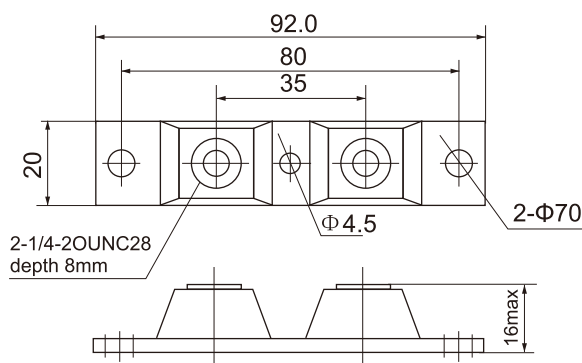

## Performance Curves

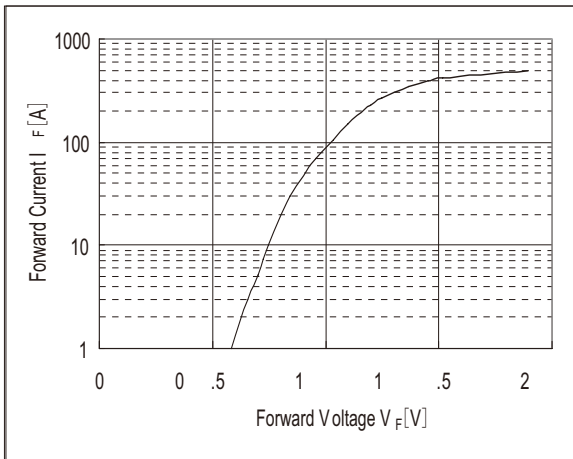

**Fig. 1 : Typical Forward Voltage Drop vs. Instantaneous Forward Current**

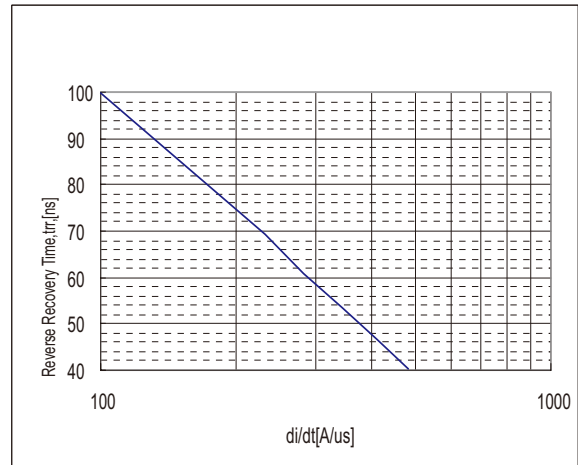

**Fig. 2 : Typical Reverse Recovery Time vs.  $-di/dt$**

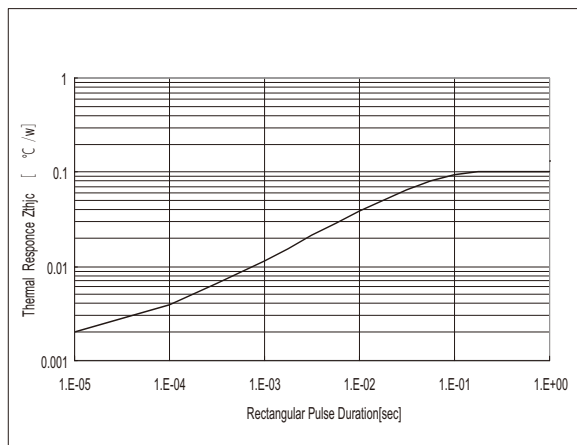

**Fig. 3 : Transient Thermal Impedance ( $Z_{thjc}$ ) Characteristics**

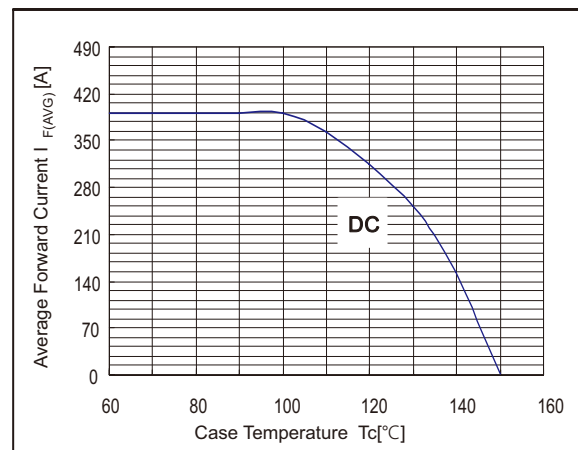

**Fig. 4 : Forward Current Derating Curve**